

Installation and Operation Guide for PD1201 Inverter Remote Display

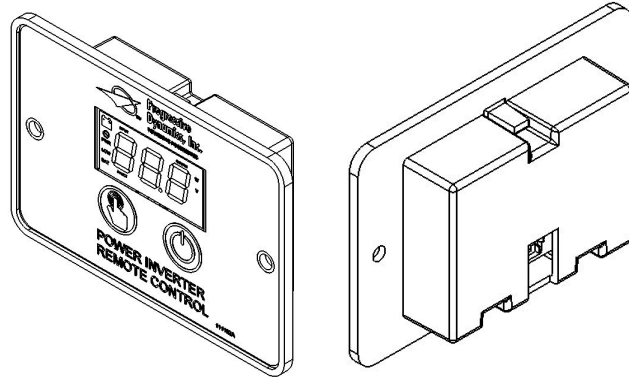

- I. **LIMITED WARRANTY:** Progressive Dynamics Warrants its power inverters to be free from defects in material or workmanship under normal use and service; and limits the remedies to repair or replacement.
- II. **DURATION:** This warranty shall extend for a period of two years from the original date of purchase, and is valid only within the continental limits of the United States and Canada.
- III. **WARRANTY EXCLUSIONS:** This warranty does not apply to:
 - A. Any product which has been repaired or altered in any way by an unauthorized person or service station
 - B. Damage caused by excessive input voltage, misuse, negligence, or accident; or an external force
 - C. Any product which has been connected, installed, or adjusted or used other than in accordance with the instructions furnished, or has had the serial number altered, defaced, or removed
 - D. Cost of all services performed in removing and reinstalling the power inverter
 - E. ANY LOST PROFITS, LOST SAVINGS, LOSS OF USE OF ENJOYMENT OR OTHER INCIDENTAL DAMAGES ARISING OUT OF THE USE OF, OR INABILITY TO USE, THE PRODUCT. THIS INCLUDES DAMAGES TO PROPERTY AND, TO THE EXTENT PERMITTED BY LAW, DAMAGES FOR PERSONAL INJURY. THIS WARRANTY IS IN LIEU OF ALL OTHER WARRANTIES, INCLUDING WARRANTIES OF MERCHANTABILITY AND FITNESS FOR A PARTICULAR PURPOSES.
- IV. **PROOF OF PURCHASE:** A warranty claim must be accompanied by proof of the date of purchase.
- V. **CLAIM PROCEDURE:** Upon discovery of a defect, Progressive Dynamics shall be supplied the following information at the address listed below:
 - A. Name and address of claimant
 - B. Name, model, and serial number of the product
 - C. Name year and model of the recreational vehicle in which the product was installed
 - D. Date of purchase
 - E. Complete description of the claimed defect

Upon determination that a warranty claim exists (a defect in material or workmanship occurring under normal use and service) the inverter shall be shipped postage prepaid to Progressive Dynamics together with proof of purchase. The product will be repaired or replaced and returned postage prepaid.

Mail Returns to: Progressive Dynamics
507 Industrial Road
Marshall, MI 49068

For Warranty Service Call: (269) 781-4242

Record the unit's model and serial number in case you need provide this information in the future. It is much easier to record this information now, instead of trying to gather it after the unit has been installed.

Model:	Serial Number:
PD1201 (Remote Display)	

Included Items & Connecting the Remote

The PD1201 Remote Display is designed for use with all PD1200 Series Inverters. The remote will allow complete monitoring of your inverter. This guide will help you install and use the remote control to monitor the functions of your inverter.

NOISE: EQUIPMENT DAMAGE

This PD1201 Remote Display User Guide is in addition to, and incorporate by reference, the relevant product information for each product in the PD1200 Series Inverter. Before reviewing this guide, you must read the relevant product manual. Unless specified, information on safety, specifications, installation, and operation is as shown in the primary documentation. Ensure you are familiar with that information before proceeding.

Failure to do follow these instruction will result in your inverter to not function properly.

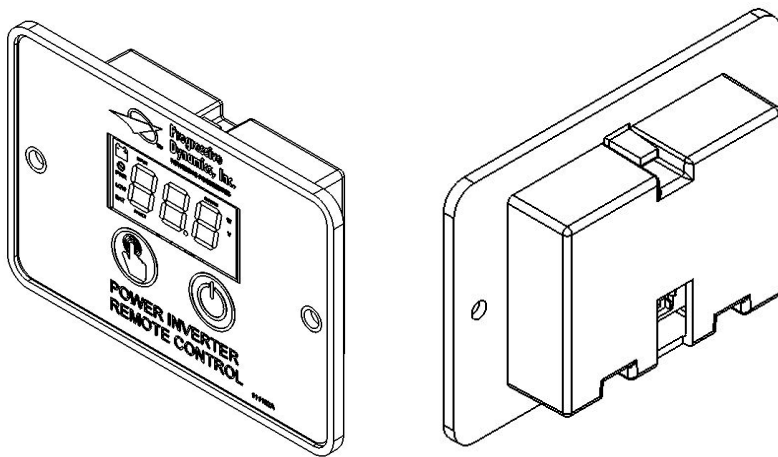

Figure 1 Inverter Remote (25' communication cable not shown)

Materials List

The PD1200 series inverter base package includes the following items:

- (1) PD1200 series inverter remote
- (1) Owner's guide & mounting template
- (1) 25' connection cable (included)

NOTE: If any of the items are missing, contact Progressive Dynamics for replacement.

Connecting the remote to the inverter

Plug the connector plug into the port on the top of the inverter and the back of the remote control using the supplied communication cable (see Figure 2). Failure to use the supplied communication cable may result in damage to the PD1201 Remote Display.

It is recommended that you install the remote into the desired location prior to connecting the cable to the remote and the inverter. Please refer to the installation portion of this guide for those instructions.

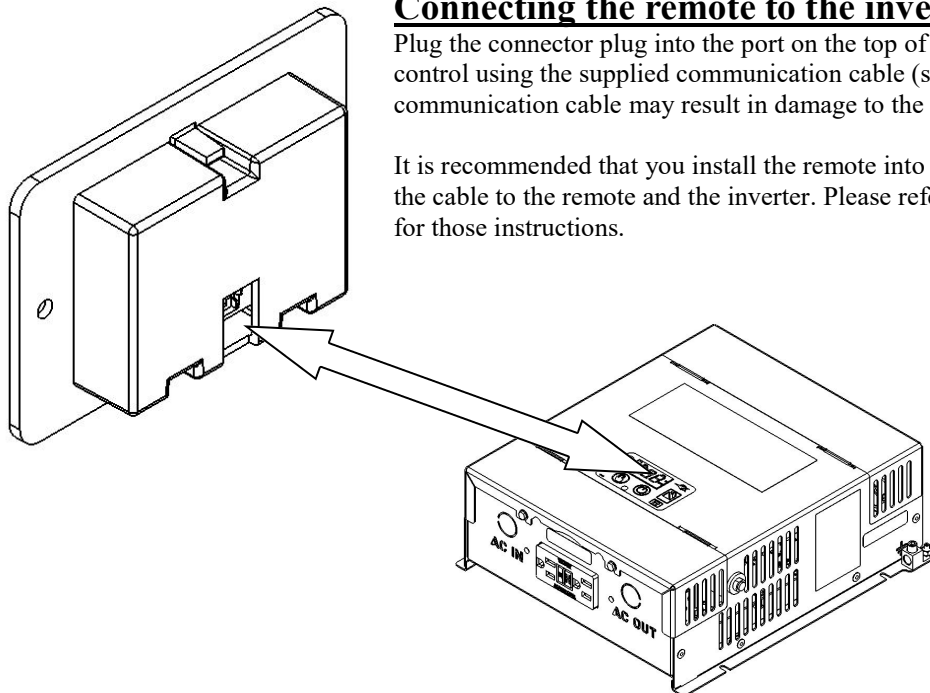

Figure 2 Connecting communication cable

Verifying connection

Once the remote display is securely connected to the PD1200 Series Inverter and the inverter is turned on, it will begin displaying readouts immediately. If your remote control display does not begin to display information, confirm that the communication cable is secured connected into both ports on the inverter and the remote control.

Using the Controls

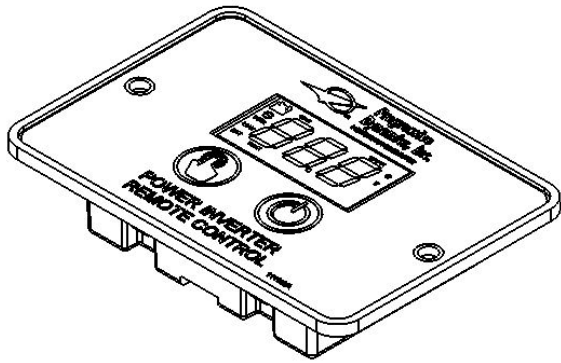

Figure 3 Inverter Remote Display

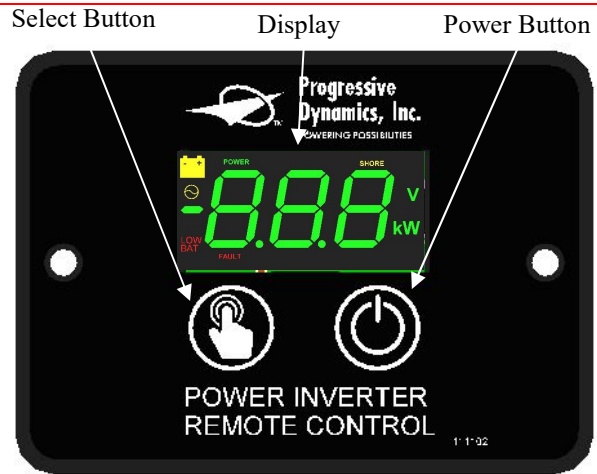

Figure 4 Remote Display Panel

Display Features

- Power Button: Press to turn on; hold to turn off
- Select Button: Cycles between display states: Input Voltage, Output Voltage, Output Power, Sleep, Error Code (if applicable)
- Power Indicator: Lights up green when the inverter is on
- Fault Indicator: Flashes red when an error has occurred
- Shore Indicator: Lights up yellow when AC input is detected
- Low Bat Warning Indicator: Lights up red when the battery is nearing the end of its charge
- Sleep: Lights automatically dim after 30 seconds

ERROR CODES		
Error Code	Condition	Description
E-1	Low battery voltage detected	Input voltage has dropped beneath 10.5V for several seconds. The PD1200 Series inverter will automatically restart when the input voltage reaches 12.0V.
E-2	High battery voltage shutdown	Input voltage has surpassed 15.5V. The PD1200 Series inverter will automatically restart when the input voltage falls below 15.0V.
E-3	AC output overload shutdown	Output power has surpassed the continuous power limit or the peak power limit. The PD1200 Series inverter will not automatically restart. A manual restart is necessary
E-4	Over-temperature shutdown	Internal temperature of the inverter has exceeded its safe operating limit. The PD1200 Series inverter will automatically restart when internal temperatures return to safe operating conditions.
E-5	Internal Error	An internal error has been detected. The PD1200 Series inverter will not automatically restart. A manual restart is necessary

NOTE: For all error codes consult page 16 in the Installation and Operation Guide for troubleshooting methods

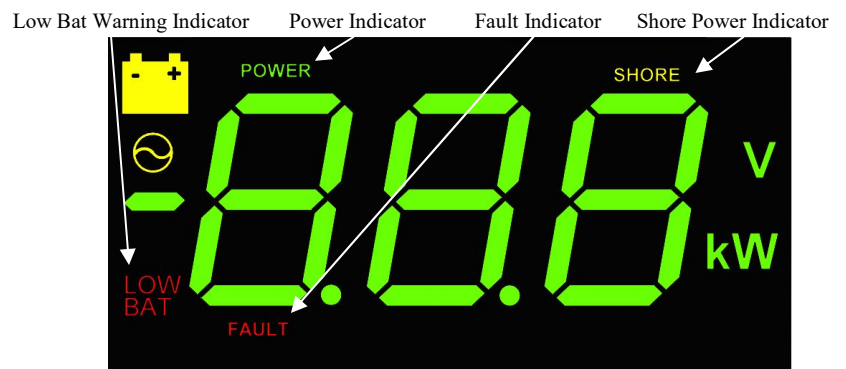

Figure 5 Display Indicators

Consult a licensed electrician or RV technician for installation assistance

Installation Template

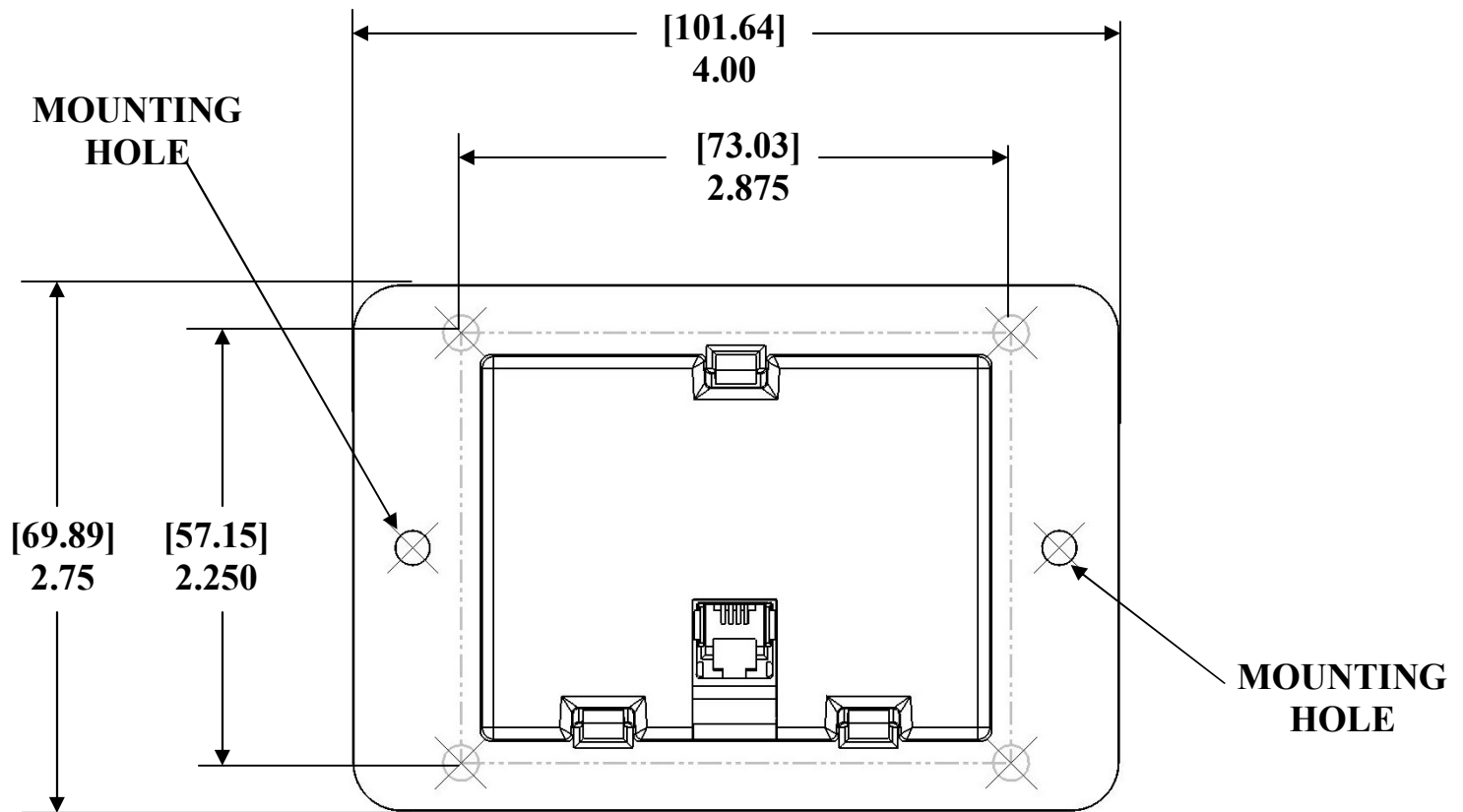

Figure 5 PD1201 Remote Display Mounting Template

Installing the remote display on the wall

1. Place the template on the wall.
2. Mark the corners (or trace the dotted lines) of the recess outline on the wall.
3. Mark the two mounting holes for the two screws on the wall.
4. Remove the template from the wall.
5. Cut along the recess outlines on the wall to make a hole for the remote control.
6. Pre-drill the mounting holes appropriate to the mount screws (not provided) that will be used.
7. Connect the communication cable to the RJ9 port on the inverter and the remote control (see Figure 2).
8. Mount the remote panel unit on the wall.

Note:

Ensure that there are no Obstructions present, such as:

- Pipes
- Insulation
- Electrical Wiring

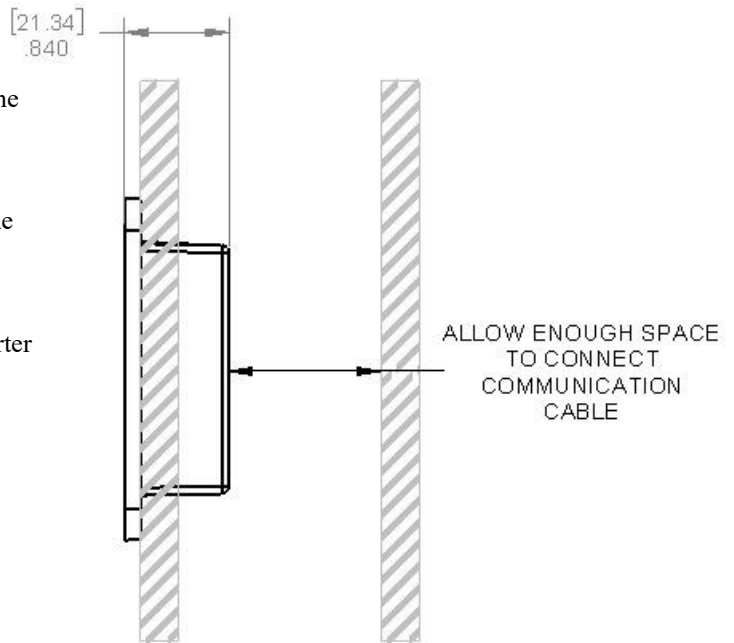

Figure 6 Mounting Diagram

Ensure that there is at no less than 1" (25.4 mm) of space for communication cable.