



- I. **LIMITED WARRANTY:** Progressive Dynamics Warrants its power inverters to be free from defects in material or workmanship under normal use and service; and limits the remedies to repair or replacement.
- II. **DURATION:** This warranty shall extend for a period of two years from the original date of purchase, and is valid only within the continental limits of the United States and Canada.
- III. **WARRANTY EXCLUSIONS:** This warranty does not apply to:
- Any product which has been repaired or altered in any way by an unauthorized person or service station
 - Damage caused by excessive input voltage, misuse, negligence, or accident; or an external force
 - Any product which has been connected, installed, or adjusted or used other than in accordance with the instructions furnished, or has had the serial number altered, defaced, or removed
 - Cost of all services performed in removing and reinstalling the power inverter
 - ANY LOST PROFITS, LOST SAVINGS, LOSS OF USE OF ENJOYMENT OR OTHER INCIDENTAL DAMAGES ARISING OUT OF THE USE OF, OR INABILITY TO USE, THE PRODUCT. THIS INCLUDES DAMAGES TO PROPERTY AND, TO THE EXTENT PERMITTED BY LAW, DAMAGES FOR PERSONAL INJURY. THIS WARRANTY IS IN LIEU OF ALL OTHER WARRANTIES, INCLUDING WARRANTIES OF MERCHANTABILITY AND FITNESS FOR A PARTICULAR PURPOSES.
- IV. **PROOF OF PURCHASE:** A warranty claim must be accompanied by proof of the date of purchase.
- V. **CLAIM PROCEDURE:** Upon discovery of a defect, Progressive Dynamics shall be supplied the following information at the address listed below:
- Name and address of claimant
 - Name, model, and serial number of the product
 - Name year and model of the recreational vehicle in which the product was installed
 - Date of purchase
 - Complete description of the claimed defect

Upon determination that a warranty claim exists (a defect in material or workmanship occurring under normal use and service) the inverter shall be shipped postage prepaid to Progressive Dynamics together with proof of purchase. The product will be repaired or replaced and returned postage prepaid.

Mail Returns to: Progressive Dynamics
507 Industrial Road
Marshall, MI 49068

For Warranty Service Call: (269) 781-4242

For Full User's Manual Please Visit:

<https://www.progressivedyn.com/service/installation-guides/>

Record the unit's model and serial number in case you need provide this information in the future. It is much easier to record this information now, instead of trying to gather it after the unit has been installed.

Model:	Serial Number:
PD1210 (1000 watt)	

Mounting Instructions

Mounting Instructions

- Inverter may be installed horizontally or vertically. Vertical installations should be sure to protect the inverter from foreign debris falling inside the unit through the ventilation slots
- External strain relief should be used for DC input wires
- Inverter can be secured to a flat surface using the side mounting slots. See Figure 2 for mounting hole pattern

⚠ WARNING: FIRE, SHOCK, AND ENERGY HAZARD

Inverter should only be installed by an electrician or a certified RV technician.

Inverter is NOT ignition protected. Do not mount in the LP gas or battery compartments

Inverter should be mounted in a dry, well ventilated space with adequate air flow

Failure to follow these instructions may result in serious injury or death. Failure to follow these instructions may also damage the unit and/or equipment.

AC Connection Instructions

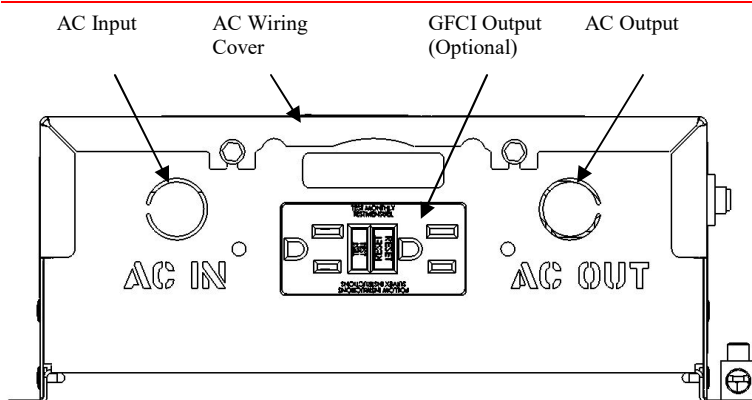

Figure 1 AC Connections Side View

Recommended GFCI for use with Inverter:

ZHANGJIAGANG CITY BAREP TECHNOLOGY CO., LTD YGB-094

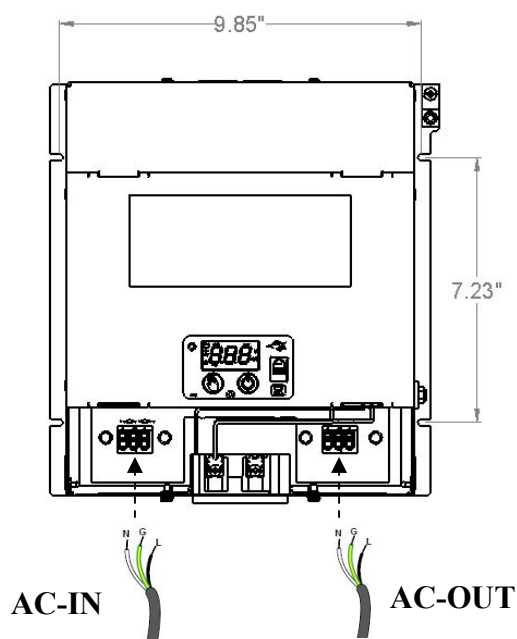

Figure 2 Mounting Hole Pattern

AC Connection Instructions

1. Ensure all power sources are disconnected from the inverter
2. Remove the AC Wiring Cover
3. Remove AC Input knockouts and AC Output knockouts (if desired)
4. Install 3/8" strain relief in AC Input and AC Output (if desired) ports
5. Connect AC Out terminal block (Ground, Neutral, and Line) to load with properly sized wires
6. Connect AC In terminal block (Ground, Neutral, and Line) to AC input with properly sized wires
7. Tighten strain relief (if applicable)

RECOMMENDED AC WIRE	STRIP LENGTH	STRAIN RELIEF
#14 AWG Solid Wire Minimum Stranded wire may be used with a corresponding ferrule	Strip 0.6" (15 mm) insulation from each wire prior to installation. Do not leave excess copper exposed.	Standard 3/8" trade strain relief

⚠ NOTICE: EQUIPMENT DAMAGE

Do not connect any AC source (such as generator or utility power) to the AC output wiring of the inverter. Connecting an AC source to the AC Output of the inverter will result in hazardous conditions.

Any directly wired AC Input and AC Output wiring must be protected with properly sized circuit protection (fuses or circuit breakers)

Failure to follow these instructions may damage the unit and/or equipment.

⚠ WARNING: FIRE, SHOCK, AND ENERGY HAZARD

Make sure wiring is disconnected from all electrical sources before handling. All wiring must be done in accordance with local and national electrical wiring codes.

DO NOT disassemble the inverter. It does not contain any user serviceable parts. Attempting to service the unit yourself could result in an electrical shock or burn.

Failure to follow these instructions may result in serious injury or death.

Consult a licensed electrician or RV technician for installation assistance

DC Connection Instructions

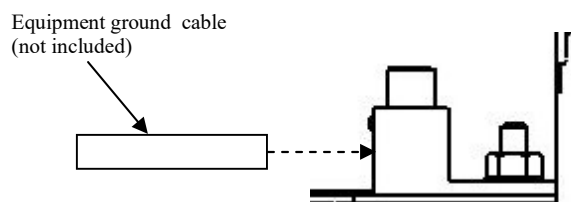

Figure 3 Connecting the Grounding cable using grounding lug

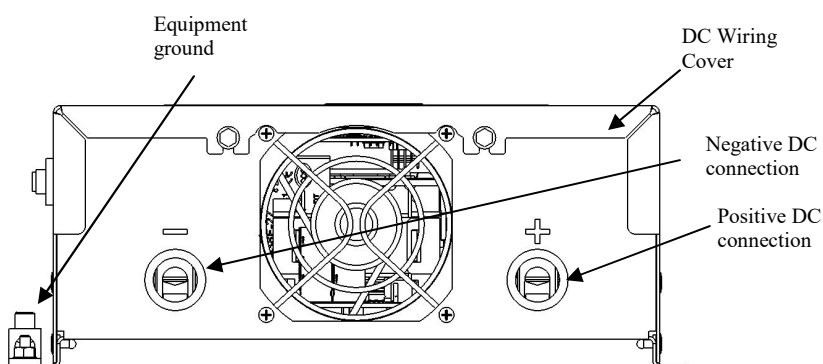

Figure 4 DC Connections Side View

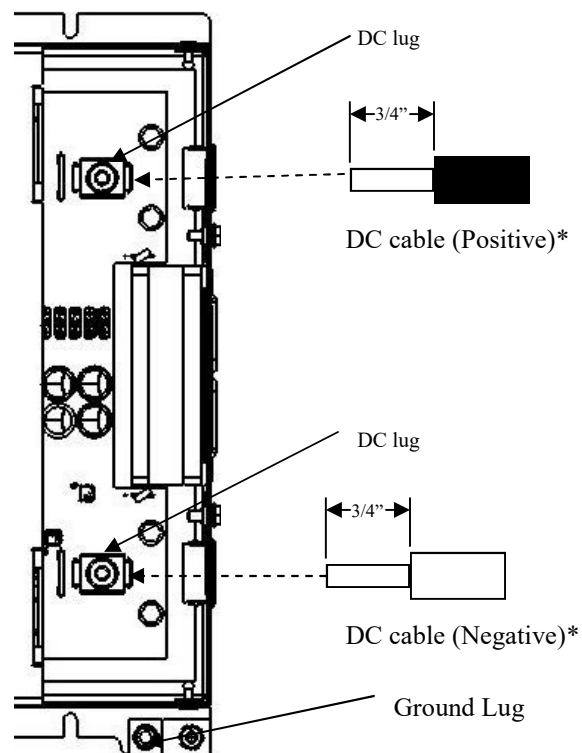

Figure 5 DC Connections With Wiring Cover Removed

MINIMUM RECOMMENDED DC WIRE SIZE		STRIP LENGTH	TORQUE DATA
Wire Length	Wire Size	Strip 3/4" (19 mm) insulation from each cable prior to installation. Do not leave excess copper exposed.	Tighten the all lugs to a torque of 100 in-lbs (11.3 N-m). <u>Do not over tighten.</u>
0-5 ft.	#2 AWG		
5-10 ft.	#1 AWG		
10-15 ft.	#1/0 AWG		

NOTE: To ensure optimum performance all input wires should be as short as possible. Failure to meet minimum recommended wire size will result in reduced performance

DC Connection Instructions

1. Ensure all power sources are disconnected from the inverter
2. Remove the DC Wiring Cover
3. Connect DC terminals (positive and negative) to battery with properly sized wires using a 5/32" hex key
4. When connecting DC wires a small spark may occur. This is normal charging of the inverter's internal capacitors
5. Re-secure the DC Wiring Cover
6. Connect equipment ground stud to a grounding point - typically the vehicle's chassis - using recommended wire. See figure 3 for recommended equipment ground connection.

⚠ WARNING: FIRE, SHOCK, AND ENERGY HAZARD

Make sure wiring is disconnected from all electrical sources before handling. All wiring must be done in accordance with local and national electrical wiring codes.

Failure to follow these instructions may result in serious injury or death.

⚠ WARNING: FIRE HAZARD

DC Input wiring must be protected with properly sized circuit protection (fuses or circuit breakers)

Never operate the inverter without properly connecting the equipment ground.

Tighten the nuts on terminals properly. Loose connections cause excessive voltage drop and may cause overheated wires and melted insulation. DO NOT under tighten the screw on the terminal lugs. This will cause the wires to lose connection.

Failure to follow these instructions may result in serious injury or death. Failure to follow these instructions may also damage the unit and/or equipment.

Inverter Display Panel

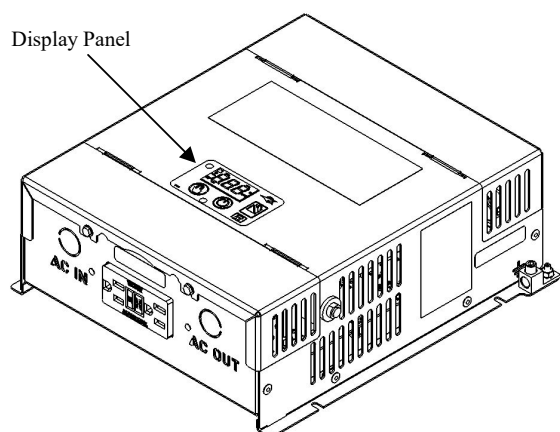

Figure 6 Inverter Display Location

Display Features

- Power Button: Press to turn on; hold to turn off
- Select Button: Cycles between display states: Input Voltage, Output Voltage, Output Power, Standby, Error Code (if applicable)
- Power Indicator: Lights up green when the inverter is on
- Shore Indicator: Lights up yellow when AC input is detected
- Low Bat Warning Indicator: Lights up red when the battery is nearing the end of its charge
- Remote port for externally mounted display

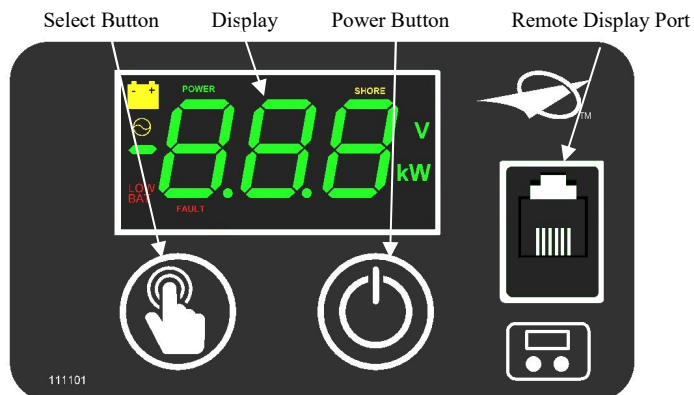

Figure 7 Display Panel

ERROR CODES		
Error Code	Condition	Action
E-1	Low battery voltage detected	<ul style="list-style-type: none"> • Re-charge the battery • Check DC cable size • Tighten DC connections
E-2	High battery voltage shutdown	<ul style="list-style-type: none"> • Disconnect external sources (alternator or charger)
E-3	AC output overload shutdown	<ul style="list-style-type: none"> • Evaluate the loads connected to the AC outlet of the unit. Loads may need to be reduced. • Check the surge rating of any appliance connected to the output
E-4	Over-temperature shutdown	<ul style="list-style-type: none"> • Reduce load to the AC output • Ensure that the inverter is in a dry, well ventilated space with adequate air flow • Ambient temperature may be too high.
E-5	Internal Error	<ul style="list-style-type: none"> • Ensure all connections are tightened • Contact the PDI Service Department

SPECIFICATIONS

Physical		Transfer Switch	
Dimensions	L = 11.6" (294.6 mm) W = 10.6" (269.2 mm) H = 4.0" (101 mm)	Transfer Voltage	100 VAC
Net Weight	7 lbs (3.2 kg)	Transfer Time	< 50 msec
		Pass Through Ampacity	15 AAC
AC Output		DC Input	
Output Voltage	120 VAC	Under-Voltage Shutdown	10.5 VDC
Output Power (Continuous)	1000 W	Under-Voltage Restart	12.0 VDC
Output Power (Peak)	2000 W	Over-Voltage Shutdown	15.5 VDC
Frequency	60 Hz	Over-Voltage Restart	15.0 VDC
Waveform	Pure Sine Wave	Nominal Voltage	12.0 VDC
Peak Efficiency	90%	Nominal Current @ max load	100 ADC

*All ratings at 25 °C unless otherwise listed

Consult a licensed electrician or RV technician for installation assistance