

from progressive dynamics

dependable power!



PD-703 - 705

YOU CAN NOW . . . Operate from a 12 volt battery or from a standard 115 volt electrical outlet. Your Electronic Power Converter automatically does all the rest. For Marine or Recreational Vehicle applications.

Join the better traveling crowd with . . .



PROGRESSIVE DYNAMICS, INC.
MARSHALL, MICHIGAN

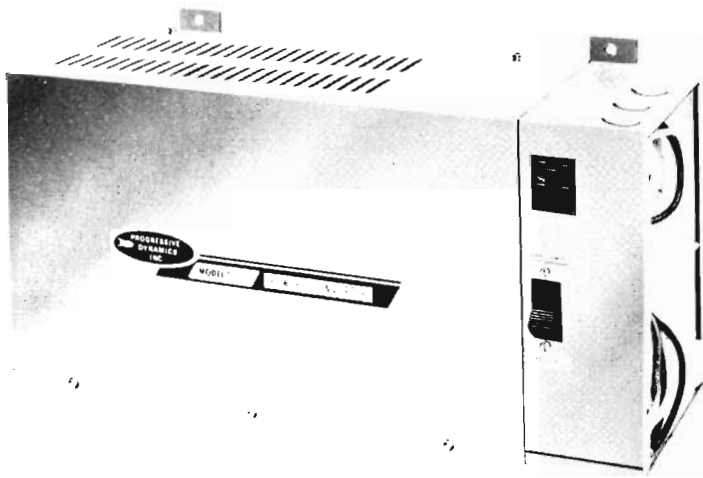

POWER CONVERTER FOR VERTICAL INSTALLATION

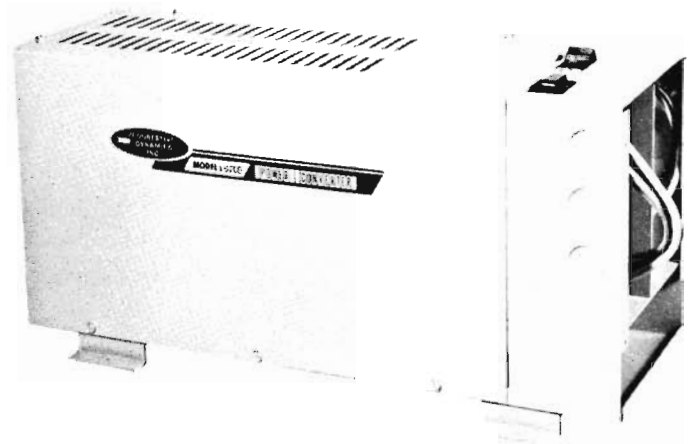

POWER CONVERTER FOR HORIZONTAL INSTALLATION

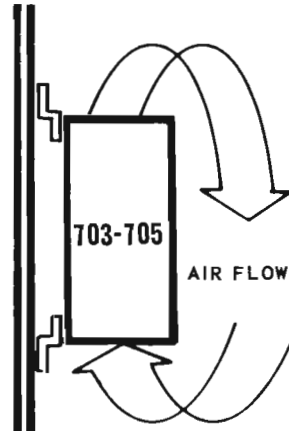

VERTICAL INSTALLATION

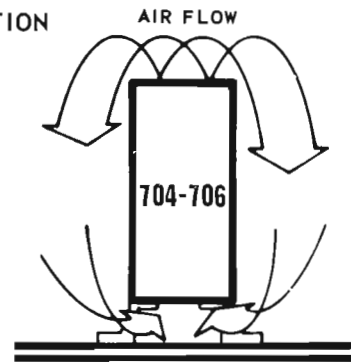

HORIZONTAL INSTALLATION

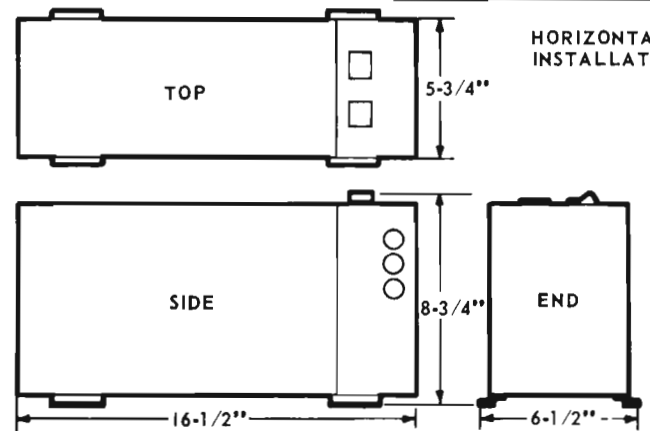
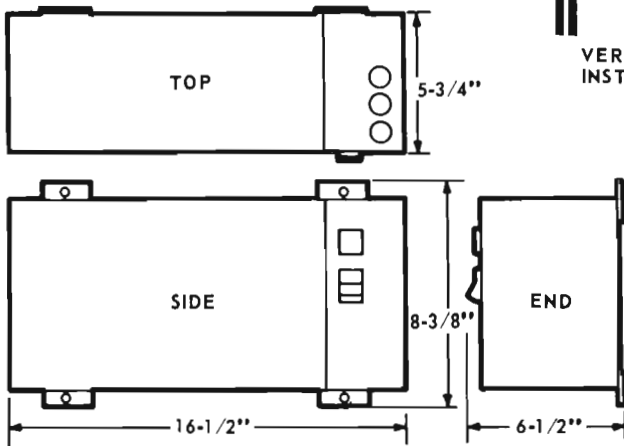

WITH THE PROGRESSIVE DYNAMICS ELECTRONIC POWER CONVERTER, HERE ARE A FEW MORE BENEFITS YOU GET:

PROTECTION AGAINST ACCIDENTAL REVERSAL OF BATTERY.

CIRCUIT PROTECTION AGAINST SHORTS. FOUR 15 AMP AUTOMATIC RESETTING THERMO-BREAKERS.

ELECTRONIC CIRCUIT WILL LIMIT CHARGE TO BATTERY. NO EXPLOSION OR DAMAGING OVERCHARGING OF BATTERY.

PROTECTION AGAINST DEAD SHORTS.

WILL AUTOMATICALLY CORRECT BATTERY SULFATION*.

OPTIONAL AUTOMATIC SWITCH OVER AVAILABLE.

Sulfation is a chemical process that restricts battery performance by the lead sulfate building up and crystallizing on the inside and outside of the positive and negative battery plates.

Your new electronic converter power pack equips your recreational vehicle with a 115 volt to 12 volt D.C. current. You have joined the better mobile living group. You can now operate from 115 volt A.C. and at the same time recharge the battery automatically to full charge whenever 115 volt A.C. is available. The converter allows the direct usage of power from the 115 volt source so that the reserve power of the battery can be maintained and used when 115 is not available. (CONVERTER DOES NOT CHANGE 12 VOLTS D.C. TO 115 VOLTS A.C.)

When your R.V. is used miles from power facilities, the battery will be your main source of power. Therefore, all electrical components depend upon the storage of electricity in the battery. The battery must provide the power to operate the lights, furnace, pump, electric toilets, etc. To operate from the battery, the rocker switch on the right-hand side of the converter must be depressed at the position designated battery. Your system will then be operating 100 per cent from the battery.

Whenever 115 V.A.C. is available, simply push the switch to transformer and the coach will receive the necessary 12 volt power from the converter.

If you fail to push the switch to transformer, your electronic system will continue to operate on the batteries until it's completely discharged. If this happens, merely place the switch back to transformer and you will immediately be using

D.C. converter power from the 115 volt A.C. source and at the same time be charging back the battery.

Your converter has a rating of 20 AMPs - (703-704), 25 AMPs - (705-706) continuous and 35 AMPs intermittent draw for not longer than 30 minutes.

1. Do not pile things on top of the converter. Your unit must have a free flow of air through and around the unit.
2. Do not let your unit get wet.
3. Keep as clean as possible to assure long life. The unit could be blown clean with an air line if necessary.
4. You have many lights, motors, etc. throughout your R.V. and you may want to add a few more. Your converter has a circuit breaker (15 AMP) for each 12 volt circuit in your R.V. If you have a circuit over-loaded, the circuit breakers will open and automatically reset in about 7-10 seconds. Your R.V. is designed to have lights where you need them but was not intended that you would have all lights and motors operating simultaneously. If a circuit is overloaded, merely shut off a light or two to reduce the load.
5. If your converter fails to operate, first check incoming power to your R.V. to make sure you have 115 A.C. available. Check the circuit breaker on the side of your converter, (if your Model has one). This is a push-matic breaker. (Push to reset). If no power is available at the coach, check plug connections at park hook-up. Check for defective cord. If you hear a clicking noise, something is overloaded or possibly the battery is installed backward. The **red** wire will connect to the larger **positive** post on the battery. The **white** wire connects to **negative** or ground side.

6. When connecting up for the night using the cord supplied with your R.V., be sure (if the park does not have grounded recepticals) to ground your R.V.

Be aware of low voltage and the causes. The longer the cord, the more chance for low voltage; and, consequently, dim lights and possible sluggish motor problems. **NOTE:** Your unit will operate from low voltage without harming it. When purchasing an extra cord, be sure to have at least a #12 wire cord.

If your converter did not contain the optional Electronic Battery Charger, you may at a later time purchase this unit either from your manufacturer or the local distributor or send direct to Progressive Dynamics, Inc.

All R.V.'s are not supplied with batteries or internal battery chargers.

If your R.V. is not supplied with the many available electrical conveniences, there is no need for a charger or battery. You may at a later date add these for further convenience.

If your converter unit has the optional battery charger enclosed, it will say "With Charger" on the face of the unit and will automatically bring your battery up to full charge and electronically discontinue charging at that point to protect your battery. An average battery will charge up over night to a voltage of $14.2 \pm .2$, this voltage will assure a full charge battery.

1. For a full charge battery of (1265 - 1275 specific (gravity) it is necessary to charge with a voltage of 14.2 D.C. but much above this, your battery could be ruined in a short time. Your Converter will prevent over-charging thru the use of an Electronic Control Unit. This limits the upper voltage to a value of 14.4 V.D.C. Every battery has an ampere hour capacity. The higher the ampere hour rating, the more energy it will store. To determine how long your battery will last, (assuming it is full charged), divide the amps you're using into the ampere hour rating to get the hours of operation. As an example, using a 60 ampere hour battery with one light bulb drawing two amps from the battery, it should last continually for 30 hours. Obviously, the energy in the battery should be utilized as sparingly as possible - keep the number of lights on to a minimum to conserve the stored energy.

2. A battery needs water - check at least once a month while traveling.

3. Low or dead batteries sulfate rapidly. (Sulfation restricts battery performance by the lead sulfate building up and crystalizing on the inside and outside of the positive and negative battery plates.)

A battery that has sulfated will re-charge very quickly, that is, the voltage comes up, but there is little or no energy in the battery. To de-sulfate a battery, use a slow trickle charge for 5 to 7 days.

However, the Progressive Dynamic's Power Converter will prevent sulfation of your battery automatically. When a low battery is suspected or when your battery is at "rest" for extended periods, occasionally plug in power converter to maintain your battery in a full charge condition. This in turn will prevent battery sulfation.

Your Power Converter is wired in such a manner that your battery can be charged up from your car generator as you are traveling. This will become especially useful if your converter is not equipped with the optional automatic charging unit. When properly connected, the car generator will charge the R.V. battery as well as the car battery while the motor is running. **NOTE:** See Wiring Diagram on back.

At night we recommend disconnecting the car battery from the R.V. battery to prevent the car battery from draining down.

Always fuse the wire from automobile to R.V.

PD-703 - 704 and PD-705 - 706 WIRING CIRCUIT

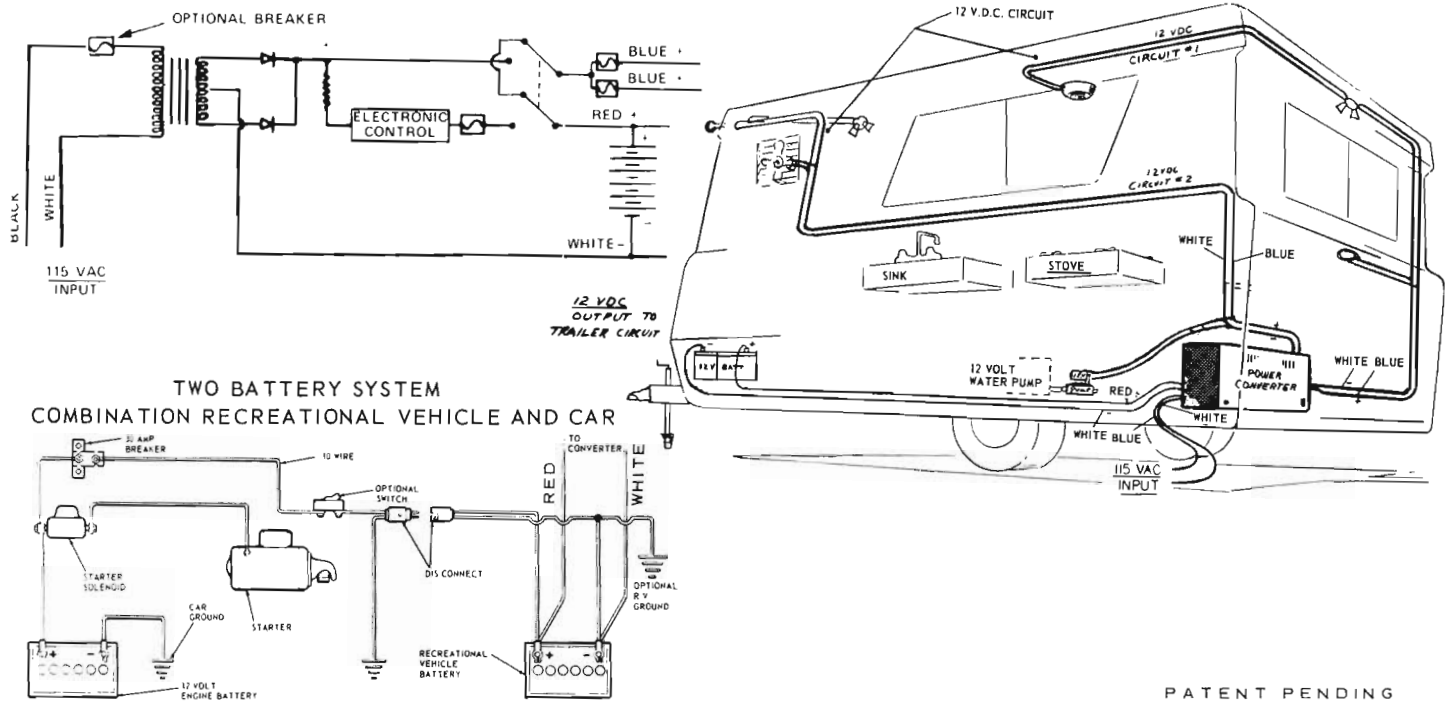

PATENT PENDING

- Input current 3.6 amps (PD-703 - 704), 4.0 amps (PD-705 - 706). 115 V.A.C. 60 cycles (acceptable input of 85 to 130 volts A.C.).
- Continuous D.C. current output 20 amps (PD-703-704), 25 amps (PD-705-706), 12.5 V.D.C.
- Two 15 amp. automatic resetting thermo-breakers, one for each 12 volt D.C. output wiring.
- Temperature operating range - 15° to 120° F.
- Battery charger, 14.2 V.D.C. .2 volt, 5 amp. rate.
- Weight 25 pounds.

D.C. current consumption of various components used within the travel trailer.

Purpose:

To provide better knowledge of the various circuits necessary and loads possible per circuit. A complete D.C. Current consumption test was run with the idea of the information being used for the design of the wiring harness of the travel trailer.

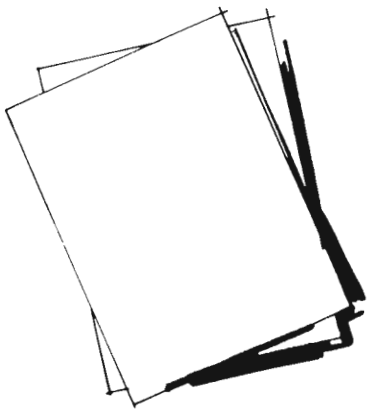

DESCRIPTION	VOLTAGE	AMPS PER HR.	NUMBER OF BULBS PER LIGHT
Bath Light #4170	12.4	4.4	3
Dinette Light #4260	12.4	5.5	4
Under Cabinet Light #4380	12.4	3.0	2
Vent Fan Model C-1010 (Range hood exhaust)	12.4	motor 3.3 light 1.5	1
		4.8 Total	
Double Bullet Light - Max.	12.4	4.0	
Single Bullet Light - Max.	12.4	1.5	1
Champion 25 Watt 12-volt light	12.4	2.2	1
Furnace Fan (Duo-Therm) Models 61901 & 61701	12.4	.8	
Humphrey Water Pump Model P-1-000	12.4	9.1 no load 10.0 loaded	
Trunk Light	12.4	1.5	1
Power Alum-Dome Fan	12.4	2.8	
Vent Fan	12.4	4.8	
Porch Light	12.4	1.5	1
Air Compressor	12.4	6.0	



PD-5



PD-306 P-12



PD-306



PD-309



PD-312



PD-325



PD-311

'The Progressive Crowd'

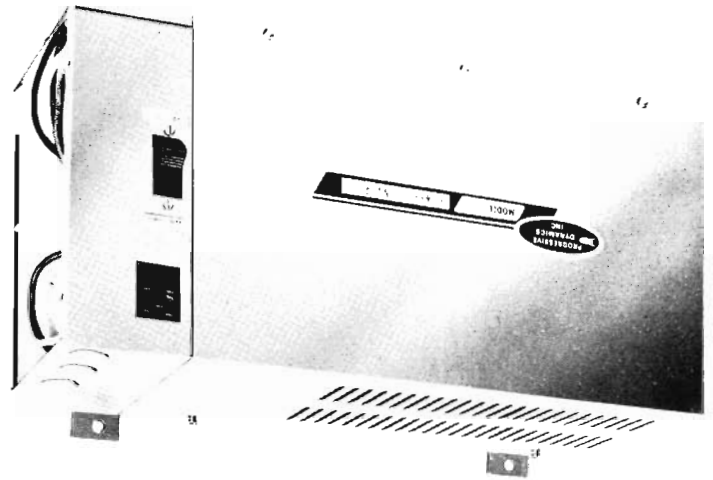

'BETTER TRAVELLING'

With today's electrical power demands in recreational vehicles, there has been much mystery and misunderstanding about the 115 volt electrical system and related 12 volt battery system. Using 115 volt outlets when available and a 12 volt battery at other times causes a basic problem of keeping this battery properly charged when you need it.

Without using a converter to solve this problem, you are faced with the following situations:

1. Paying additional money for your recreational vehicle with dual electrical appliances, one for 115 volts, one for 12 volts.
2. Constantly re-charging your battery either by a "high rate" battery charger or by a "trickle" charger.

HIGH RATE CHARGER:

- a. There is no practical way to know when your battery is at full charge. Therefore your battery can boil dry and simultaneous damage will definitely result to the battery. In 20 minutes your battery can go from 95% of full charge to overcharged and become damaged or even destroyed.
- b. "High rate" chargers are expensive.

TRICKLE CHARGER:

- a. Trickle chargers take 3 to 4 days to bring a 12 volt battery to full charge. If one 25 watt bulb was burning constantly at the same time you were charging your battery, it would never charge. The 25 watt bulb is pulling as much electricity as your trickle charger is giving.

The Electronic Converter is designed to solve these electrical/battery problems efficiently, automatically and economically.

Eugene Kilbourn, President

PROGRESSIVE DYNAMICS, INC.

MARSHALL, MICHIGAN

P.O. Box 168 507 Industrial Rd. Marshall, Michigan Zip 49068 Phone (616) 781-4241