

**PROGRESSIVE DYNAMICS, INC.  
MARINE BATTERY CHARGER LIMITED WARRANTY**

**I. LIMITED WARRANTY:** Progressive Dynamics, Inc. warrants its battery chargers to be free from defects in material or workmanship under normal use and service, and limits the remedies to repair or replacement.

**II. DURATION:** This warranty shall extend for a period of two years from the original date of manufacture and is valid only within the continental limits of the United States and Canada.

**III. WARRANTY EXCLUSIONS:** This warranty specifically does not apply to:

- A. Any battery charger which has been repaired or altered in any way by an unauthorized person or service station;
- B. Damage caused by excessive input voltage, misuse, negligence, or accident, or an external force;
- C. Any battery charger which has been connected, installed, or adjusted, or used other than in accordance with the instructions furnished, or has had the serial number altered, defaced, or removed;
- D. Cost of all services performed in removing and reinstalling the battery charger; and
- E. ANY LOST PROFITS, LOST SAVINGS, LOSS OF USE OF ENJOYMENT OR OTHER INCIDENTAL DAMAGES ARISING OUT OF THE USE OF, OR INABILITY TO USE, THE PRODUCT. THIS INCLUDES DAMAGES TO PROPERTY AND—TO THE EXTENT PERMITTED BY LAW—DAMAGES FOR PERSONAL INJURY. THIS WARRANTY IS IN LIEU OF ALL OTHER WARRANTIES, INCLUDING IMPLIED WARRANTIES OF MERCHANTABILITY AND FITNESS FOR A PARTICULAR PURPOSE.

**IV. CLAIM PROCEDURE:** Upon discovery of any defect, Progressive Dynamics, Inc. shall be supplied the following information by mail, telephone, or fax at the address listed below:

- A. Name and address of the claimant;
- B. Name and model of the battery charger;
- C. Name, year, and model of the craft in which the charger was installed;
- D. Date of purchase; and
- E. Complete description of the claimed defect.

Upon determination that a warranty claim exists (a defect in material or workmanship occurring under normal use and service), the battery charger shall be shipped postage prepaid to Progressive Dynamics, Inc. together with proof of purchase. The battery charger will be repaired or replaced and returned postage prepaid.

**Progressive Dynamics, Inc.  
507 Industrial Road  
Marshall, Michigan 49068  
Phone: 269-781-4241 Fax: 269-781-7802  
www.progressivedyn.com**



**ELECTRONIC MARINE CONVERTER/CHARGER**

**Owners Manual  
Models PD2120, PD2130, PD2140, PD2150, PD2160, PD2180**

Thank you for purchasing the **INTELL-POWER MARINE** converter/charger. The **INTELL-POWER MARINE** converter from Progressive Dynamics Inc. has been designed and manufactured to meet the harsh environmental, mechanical and electrical conditions that exist in the marine industry. The **INTELL-POWER MARINE** converter incorporates our Patented Tri-Power circuitry and modern Microcontroller technology to provide a Total Charge Management System for recharging and maintaining marine batteries by providing 4 modes of operation, Normal, Boost, Trickle and Equalization. The Converter/Chargers also incorporate a digital volt/amp meter that will display total output current and voltage readings for each output.



NOTES:

Model #: \_\_\_\_\_

Serial #: \_\_\_\_\_

Do not replace the converter unless the following checks have been performed:

1. Loosen the screw on all the positive terminals and disconnect the positive wires. Read the converter output voltage using a DC voltmeter. If the voltage is above 13 volts, the converter is working properly.
2. If the converter output is zero volts, use an AC voltmeter to check for proper voltage on the 120 VAC power source. This voltage should be between 104 and 130 volts.
3. Check the fuse(s) located next to the output terminal block inside the converter. The fuse(s) will only blow if the battery or DC output leads were connected in reverse, even for a moment. Replace the fuse(s) and repeat step 1.

### SPECIFICATIONS

#### PD2120

Input: 105-130 VAC 50/60 Hz  
350 Watts

Output: 13.9 VDC, 20 Amps

Dimensions: L= 10.2" W= 7.8" H=4.2"  
Weight: 6lbs

#### PD2140

Input: 105-130 VAC 50/60 Hz  
650 Watts

Output: 13.9 VDC, 40 Amps

Dimensions: L= 10.2" W= 7.8" H= 4.2"  
Weight: 6.25lbs

#### PD2160

Input: 105-130 VAC 50/60 Hz  
1000 Watts

Output: 13.9 VDC, 60 Amps

Dimensions: L= 10.2" W= 7.8" H= 4.2"  
Weight: 6.5lbs

#### PD2130

Input: 105-130 VAC 50/60 Hz  
550 Watts

Output: 13.9 VDC, 30 Amps

Dimensions: L= 10.2" W= 7.8" H= 4.2"  
Weight: 6.25lbs

#### PD2150

Input: 105-130 VAC 50/60 Hz  
900 Watts

Output: 13.9 VDC, 50 Amps

Dimensions: L= 10.2" W= 7.8" H= 4.2"  
Weight: 6.5lbs

#### PD2180

Input: 105-130 VAC 50/60 Hz  
1300 Watts

Output: 13.9 VDC, 80 Amps

Dimensions: L= 10.2" W= 7.8" H= 4.2"  
Weight: 8.8lbs

### Table Of Contents

<b>IMPORTANT SAFETY INSTRUCTIONS</b>	<b>4</b>
<b>PERSONAL PRECAUTIONS</b>	<b>4</b>
<b>LOCATING THE INTELL-POWER MARINE CONVERTER/CHARGER</b>	<b>5</b>
<b>DC CONNECTION PRECAUTIONS</b>	<b>6</b>
<b>INSTALLING THE INTELL-POWER MARINE CONVERTER</b>	<b>6</b>
<b>OPERATING THE INTELL-POWER MARINE CONVERTER/CHARGER</b>	<b>9</b>
<b>SELECTING BATTERY TYPE</b>	<b>9</b>
<b>MAINTAINING THE INTELL-POWER MARINE CONVERTER/CHARGER</b>	<b>12</b>
<b>TROUBLE SHOOTING GUIDE</b>	<b>12</b>
<b>SAMPLE WIRING DIAGRAMS FOR SERIES/PARALLEL CONNECTIONS</b>	<b>13</b>
<b>SPECIFICATIONS</b>	<b>14</b>
<b>MARINE BATTERY CHARGER LIMITED WARRANTY</b>	<b>Back Cover</b>

## 1. IMPORTANT SAFETY INSTRUCTIONS

**SAVE THESE INSTRUCTIONS** - This manual contains important safety and operating instructions for the **INTELI-POWER MARINE** series of electronic converter/chargers.

**CAUTION** - To reduce risk of injury, charge only Lead-Acid, AGM or Gel type rechargeable batteries. Other types of batteries may burst causing personal injury and damage. See page 9 for battery type selection.

Do not expose converter to rain, snow or excessive moisture .

Use of attachments not recommended or sold by Progressive Dynamics Inc. may result in a risk of fire, electric shock, or injury to persons.

Do not disassemble **INTELI-POWER MARINE** converter. Return it to Progressive Dynamics Inc. when service or repair is required. Incorrect re-assembly may result in a risk of electric shock or fire.

To reduce risk of electric shock, disconnect A.C. power from the **INTELI-POWER MARINE** converter before attempting any maintenance or cleaning. Turning off controls will not reduce this risk.

### WARNING - RISK OF EXPLOSIVE GASES.

**WORKING IN THE VICINITY OF A LEAD-ACID BATTERY IS DANGEROUS. BATTERIES GENERATE EXPLOSIVE GASES DURING NORMAL BATTERY OPERATION. FOR THIS REASON, IT IS OF UTMOST IMPORTANCE THAT EACH TIME BEFORE SERVICING EQUIPMENT IN THE VICINITY OF THE BATTERY, YOU READ THIS MANUAL AND FOLLOW THE INSTRUCTIONS EXACTLY.**

**To reduce risk of battery explosion, follow these instructions and those published by battery manufacturer and manufacturer of any equipment you intend to use in vicinity of battery. Review any cautionary markings on these products and on engine.**

## 2. PERSONAL PRECAUTIONS

Someone should be within range of your voice or close enough to come to your aid when you work near a lead-acid battery.

Have plenty of fresh water and soap nearby in case battery acid contact skin, clothing, or eyes.

Wear complete eye protection and clothing protection. Avoid touching eyes

## SAMPLE WIRING DIAGRAMS FOR SERIES/PARALLEL CONNECTIONS.

The Inteli-Power chargers can be wired in series to provide a 24 volt charging system. They can also be wired in parallel to provide additional charge current.

### Parallel Connection:

Wiring the Inteli-power chargers as shown below will provide additional charging current to the 12 volt house battery system and eliminates the need to install additional chargers for the engine, generator and the 12 volt bow thruster batteries.

The Parallel system shown above using PD2050 Chargers can provide a maximum of 100 amps to recharge the house battery system. It can also provide up to 50 amps to charge the engine, bow thruster or generator batteries if the house batteries are fully charged.

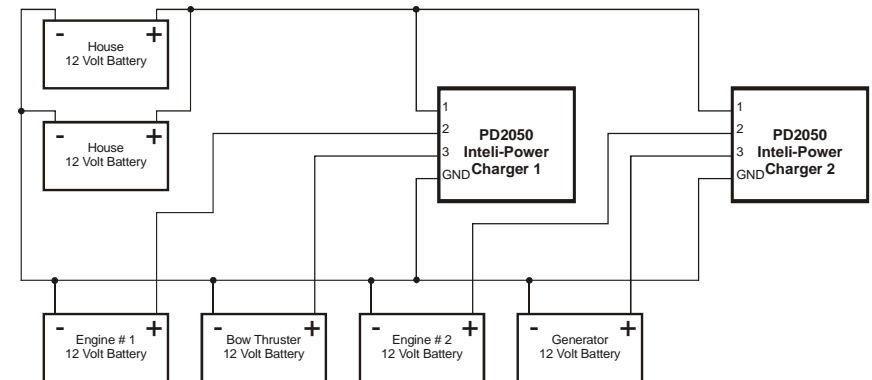

### Series Connection:

Wiring the Inteli-power chargers as shown below will provide a combination of 12 and 24 volt charging system. This can eliminate the need to install expensive battery equalizers and additional chargers for the 12 volt house and 24 volt bow thruster batteries.

The Series system shown above will provide 24 volt charging for the bow thruster and engine batteries while supplying 12 volt charging for the house battery.

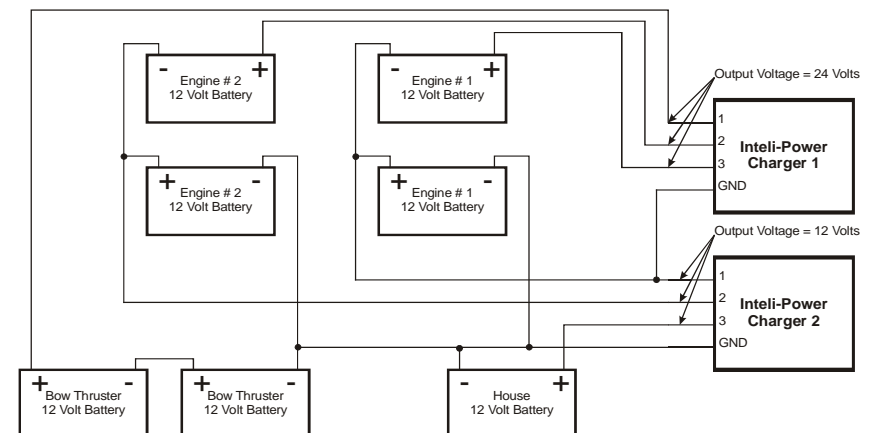

**7. MAINTAINING THE INTELI-POWER MARINE CONVERTER/CHARGER**

No adjustments or maintenance is required for the **INTELI-POWER MARINE** converter other than periodically checking all electrical connections for tightness by a qualified service person.

**CAUTION**

**Check battery water level frequently, especially if boat is at dock for extended periods of time. Low water levels will damage batteries!**

**TROUBLESHOOTING THE INTELI-POWER MARINE CONVERTER/CHARGER**

<b>PROBLEM</b>	<b>POSSIBLE CAUSES</b>	<b>ACTION</b>
1. No Output	120 VAC supply not connected	Connect power supply
		Check AC distribution panel for proper operation
	Internal Fuse(s) Blown	Check for Reverse Polarity
		Replace Fuse(s) with same type and rating
	Short Circuit	Trace Vessel Circuits for possible fault
	Unit has shutdown due to overheating	Check air flow
		Allow unit to cool
	Unit has shutdown due to over voltage	Check input voltage
		Converter will shut down if the input voltage exceeds 132 Volts
		Correct Input Voltage
2. Internal Fuse(s) Blown	Reverse Battery Hook Up	Correct Hook up and replace Fuse(s) with same type and rating
3. Converter cycles on & off	Compartment gets too hot	Check air flow to the converter
		Improve Ventilation to the compartment
4. Low Output	Excessive Load for Converter	Reduce load requirements or Install Larger Converter
	Input Voltage not between 105-130 VAC	Correct input supply voltage
	Bad Battery Cell(s)	Replace Battery

while working near battery.

If battery acid contacts skin or clothing, wash immediately with soap and water. If acid enters eye, immediately flood eye with running cold water for at least 10 minutes and get medical attention immediately.

**NEVER** smoke or allow a spark or flame in vicinity of battery or engine.

Be extra cautious to reduce risk of dropping a metal tool onto battery. It might spark or short-circuit battery or other electrical part that may cause explosion.

Remove personal metal items such as rings, bracelets, necklaces, and watches when working with a lead-acid battery. A lead-acid battery can produce a short-circuit current high enough to weld a ring or the like to metal, causing a severe burn.

**NEVER** charge a frozen battery.

If necessary to remove battery from vessel, always remove grounded terminal from battery first. Make sure all accessories in the vessels are off, so as not to cause an fire.

Be sure area around battery is well ventilated.

Clean battery terminals. Be careful to keep corrosion from coming in contact with eyes.

Study all battery manufacturer's specific precautions such as removing or not removing cell caps while charging and recommended rates of charge.

Add distilled water in each cell until battery acid reaches level specified by battery manufacturer. This helps purge excessive gas from cells. Do not overfill. For a battery without cell caps, carefully follow manufacturer's recharging instructions.

**3. LOCATING THE INTELI-POWER MARINE CONVERTER/CHARGER**

Locate the converter/charger in a well ventilated compartment. Never place the converter/charger directly above the battery; gases from battery will corrode and damage the converter/charger.

Never allow battery acid to drip on converter/charger when reading specific gravity or filling battery.

Do not operate converter/charger in a closed-in area or restrict ventilation in any way.

#### 4. DC CONNECTION PRECAUTIONS

Connect and disconnect DC output connections only after opening AC disconnect.

**EXTERNAL CONNECTIONS TO CONVERTER SHALL COMPLY WITH THE UNITED STATES COAST GUARD ELECTRICAL REGULATIONS (33CFR183, SUB PART I).**

**GROUNDING INSTRUCTIONS** - The *INTELI-POWER MARINE* converter should be connected to a grounded, metal, permanent wiring system. An equipment-grounding conductor should be run with the circuit wiring and connected thru the charger housing grommet to the equipment grounding (GND) terminal. Connections to the converter should comply with all local codes and ordinances.

Never place the converter/charger directly above the battery; gases from battery will corrode and damage the converter/charger.

#### 5. INSTALLING THE INTELI-POWER MARINE CONVERTER ! DANGER !

**Before working on any electrical equipment, first determine that there is no live power! Double check power connections, as well as battery terminations.**

#### MOUNTING LOCATION

Mount the *INTELI-POWER MARINE* converter vertically flush on a bulk-head in a protected area away from rain or spray. Mount as close to the batteries as possible. Ensure that there is six inches of unobstructed area on all sides of the charger for air circulation and cooling. See section 3 for precautions.

#### MOUNTING HARDWARE

Marine equipment is exposed to severe mechanical vibration and shock, the screws or bolts used to mount the charger must be 3/16" diameter, backed with a flat washer. A lock washer should be used to prevent loosening of the connections due to vibration.

#### MOUNTING THE CONVERTER

Hold the converter/charger in place, mark all mounting hole positions, remove the converter/charger and drill the holes. Mark and drill mounting holes as above. Attach the drip shield leaving the screws loose. Position the keyholes over the screws holding the drip shield and slide the unit in place. Install the rest of the mounting hardware and firmly tighten. See Figure 1.

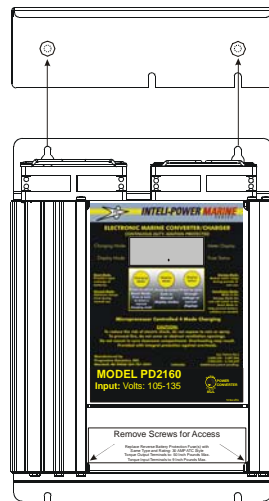

Figure 1

#### CHARGING MODE BUTTON

Press this button to force the unit into the BOOST mode for 4 hours. Press and hold to cycle between BOOST, STORAGE and NORMAL modes.

#### DISPLAY MODE and DISPLAY SELECT BUTTONS

At power up the display is in the AUTOMATIC scan mode, in this mode the meter reading will continuously cycle through BATTERY TYPE, V1,V2,V3 voltages and TOTAL output current readings.

The display can be set to a manual mode by pressing and releasing the DISPLAY MODE button, the user will see the display mode icon on the LCD display change from AUTO to MANUAL. While in MANUAL mode pressing the DISPLAY SELECT button will cycle through the display modes with each press. NOTE: in manual mode the display will show Battery Type, VDC—internal charger voltage, V1—Output 1 Voltage, V2—Output 2 Voltage, V3—Output 3 Voltage and Total Output Current.

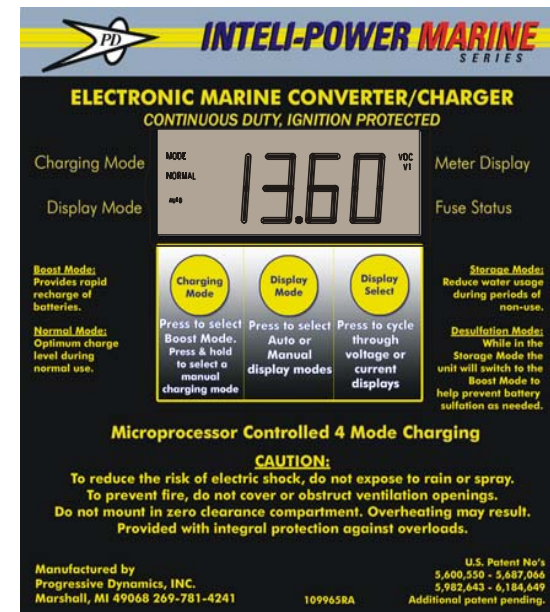

#### REVERSE BATTERY FUSES

The PD2100 Series chargers are protected from reverse battery connections by the use of ATC type fuses. If these fuses are blown the digital display will flash Err, while the Mode indicator and Fuse Status indicator will flash on and off at 1/2 second intervals while the unit has AC power. To change the fuse(s), remove the screws securing the access panel and open the panel. The fuse(s) are located directly above the negative battery terminal inside the unit. Replace the fuse(s) with only the same type and rating, 30 Amp ATC fuse(s).

### NORMAL MODE:

In the normal mode the output voltage is set at 13.9 volts DC. This voltage provides good charging rates and low water usage.

### BOOST MODE:

If the **INTELI-POWER MARINE** converter/charger senses the battery voltage has dropped below a preset level, the system automatically switches into the Boost Mode. In this mode the charge voltage is increased to 14.4 volts for a period of approximately 4 hours.

### TRICKLE MODE:

When the **INTELI-POWER MARINE** converter/charger senses that there has been no significant battery usage for a period of approximately 30 hours the charge voltage is automatically reduced to 13.2 volts DC for minimal water usage until the unit senses usage of the electrical system.

### STORAGE/EQUALIZATION MODE:

When the charger is in the Storage Mode, the microprocessor automatically equalizes the battery by increasing the charging voltage to 14.4 volts for 15 minutes every 21 hours. This causes the battery to gas for a short time and re-mixes the electrolyte to prevent the buildup of sulfation on the battery plates. While the unit is equalizing the battery the storage and boost indicators on the display will be on, the boost indicator will turn off when equalization is completed.

### FRONT PANEL AND DISPLAY OPERATION

The digital display on the front of the unit will display output voltage for each output and total charger output along with the current operating mode.

1. Displays current operational mode. (flashes when in manual mode)
2. Indicates Auto or Manual display scan mode. (flashes when in manual mode)
3. Meter is reading total output current.
4. Displays which output is being measured
5. Reverse Battery Fuse Indicator, Flashes when fuses are open.

For readings above the measurement range the meter will display OL.

For readings below the measurement range the meter will display Err.

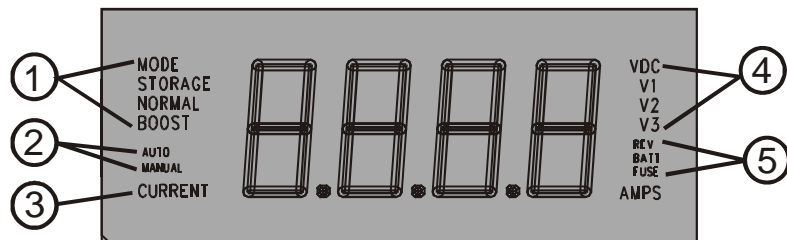

### ELECTRICAL HARDWARE

This equipment is designed for hard-wiring in a permanent application. Appropriate marine electrical installation hardware should be used.

### CHOOSING WIRE GAUGE

Connections to the **INTELI-POWER MARINE CONVERTER** shall comply with U.S. Coast Guard Electrical Regulations (33CFR183 subpart I)

### AC CONNECTIONS

After the appropriate wire gauges and lengths have been determined, make connections to the AC input terminal block (see Figure 2). To make connections to the terminal block, remove the cover retaining screws and open the access panel. Feed the AC wiring through the access hole near the AC terminal block. The terminals are labeled for proper AC connections, The White wire should be connected to the terminal marked NEU, the Black wire to the terminal marked HOT, and the Green wire should be connected to the terminal marked GND. Torque connections to 9 inch lbs.

### DC CONNECTIONS

After the appropriate wire gauges and lengths have been determined, make connections to the DC output terminal block (see Figure 2). Feed the DC wiring through the access hole near the DC outputs. The terminals are labeled for proper DC connections, the **INTELI-POWER MARINE** converter has three positive (+) terminals for up to three battery banks. One common negative (-) terminal is provided for connection to all battery banks. Torque connections to 16 inch lbs for PD2120 to PD2140 or 25 inch lbs for PD2150 to PD2180.

### INSTALLING EXTERNAL FUSE(S) (not supplied)

An external fuse or circuit breaker (not provided) must be installed within 72 inches of the battery on each positive (+) DC output wire that is connected to a battery bank. (Figure 2)

### FINAL WIRING CHECK

Make sure all electrical connections have been properly made to each battery bank and at the **INTELI-POWER MARINE** converter. Also check that all wiring is properly dressed with no exposed, bare wires. Close the access door and secure with the screws removed in sections 5.

### NOTICE

**Before placing the unit in service the battery type must be set to the proper cell type. The Inteli-power Marine 2100 Series converters are user adjustable for the three types of batteries commonly used in the marine industry Lead Acid, AGM and GEL .**

**All batteries in the system should be of the same construction. See Page 9 for instructions for setting battery type.**

**NOTE: Read This Manual and all Precautions Before Installing or Making Connections!**

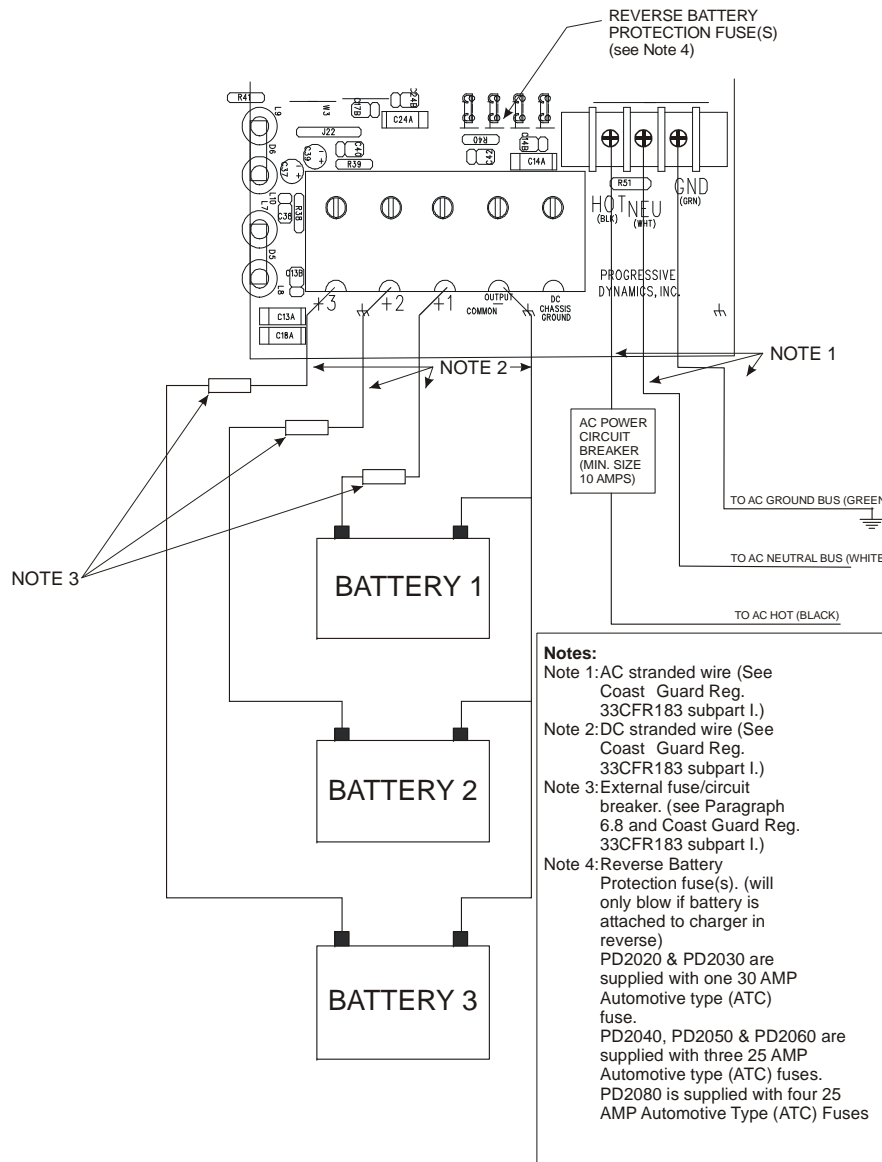

Figure 2

Approximate output voltages for cell type settings

	Storage	Normal	Boost
Lead Acid	13.3VDC	13.9VDC	14.4VDC
AGM	12.8VDC	13.3VDC	13.9VDC
Gel Cell	12.8VDC	13.3VDC	13.9VDC

**DANGER**

**Under no circumstances should the *INTELI-POWER MARINE CONVERTER/CHARGER* be operated with the access cover removed.**

**6. OPERATING THE *INTELI-POWER MARINE CONVERTER/CHARGER***

Always follow all precautions in the IMPORTANT SAFETY INSTRUCTIONS in Part 1 of this manual.

**SELECTING BATTERY TYPE**

All units are set for LEAD ACID batteries from the factory. To change the selected charge profile apply power to the unit, and wait for the unit to complete the self test, press and hold the DISPLAY MODE button, after 5 seconds the display will indicate the battery type. (LA for Lead Acid, GEL for Gel Cell, AG for AGM batteries) To change the charge profile for a different battery type press and hold the DISPLAY MODE button until the unit displays the current battery type, while holding the DISPLAY MODE button press and release the DISPLAY SELECT button to cycle through the different charging profiles, when the proper battery type is displayed release the DISPLAY MODE button to save the settings.

**APPLYING POWER**

Apply shore power to the unit and turn on the AC power source circuit breaker. The display mounted on the front of the *INTELI-POWER MARINE* converter will turn on all display elements for about 1 second. The unit will then cycle through each of the 3 modes Storage, Normal, and Boost pausing for about 1 second at each setting. When the self test is complete the unit will default to the Normal mode unless one or more of the batteries has a low charge. If the *INTELI-POWER MARINE* converter does not charge batteries or perform as above refer to the trouble shooting chart for more information.

**PROPER OPERATION**

When properly installed and connected, the *INTELI-POWER MARINE* converter/charger will monitor the battery condition then automatically select one of it's operating modes to provide the correct charging level. (all stated voltages are for the lead acid battery setting)